



(19) **United States**

(12) **Patent Application Publication**
Lee et al.

(10) **Pub. No.: US 2008/0088548 A1**
(43) **Pub. Date: Apr. 17, 2008**

(54) **ORGANIC LIGHT EMITTING DIODE
DISPLAY DEVICE AND DRIVING METHOD
THEREOF**

(30) **Foreign Application Priority Data**

Oct. 12, 2006 (KR) 10-2006-0099349

Publication Classification

(76) Inventors: **Jae Sung Lee**, Suwon-si (KR);
Chang Hoon Lee, Suwon-si (KR)

(51) **Int. Cl.**
G09G 3/30 (2006.01)

(52) **U.S. Cl.** **345/77**

(57) **ABSTRACT**

An organic light emitting diode display device is disclosed. The device includes a brightness controller configured to selectively control a brightness controlling range based at least in part on the magnitude of the video data input in one frame, and a gamma correcting unit configured to control the portion of maximum luminance corresponding to full scale data based on one of first gamma correcting values and second gamma correcting values.

Correspondence Address:
KNOBBE MARTENS OLSON & BEAR LLP
2040 MAIN STREET, FOURTEENTH FLOOR
IRVINE, CA 92614

(21) Appl. No.: **11/901,090**

(22) Filed: **Sep. 13, 2007**

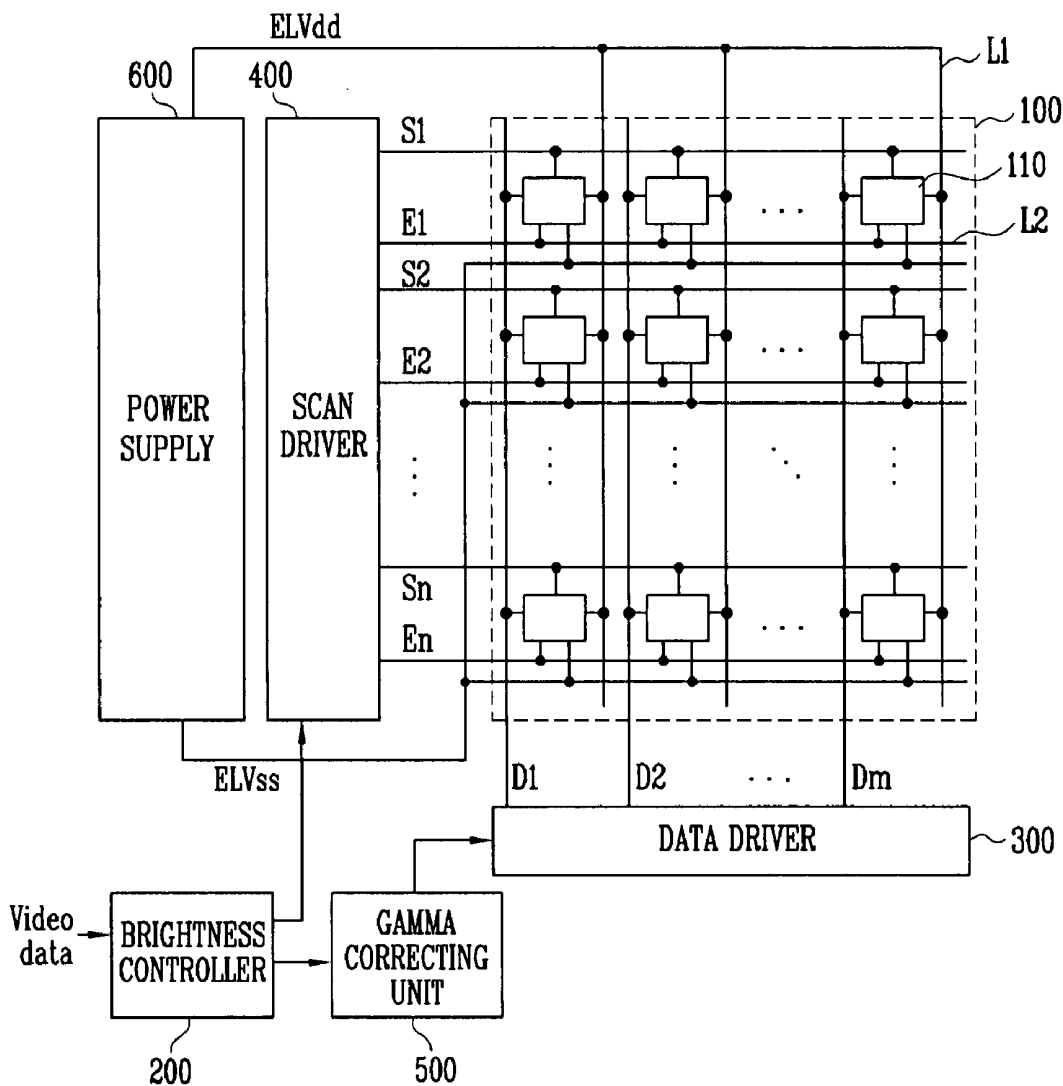

FIG. 1

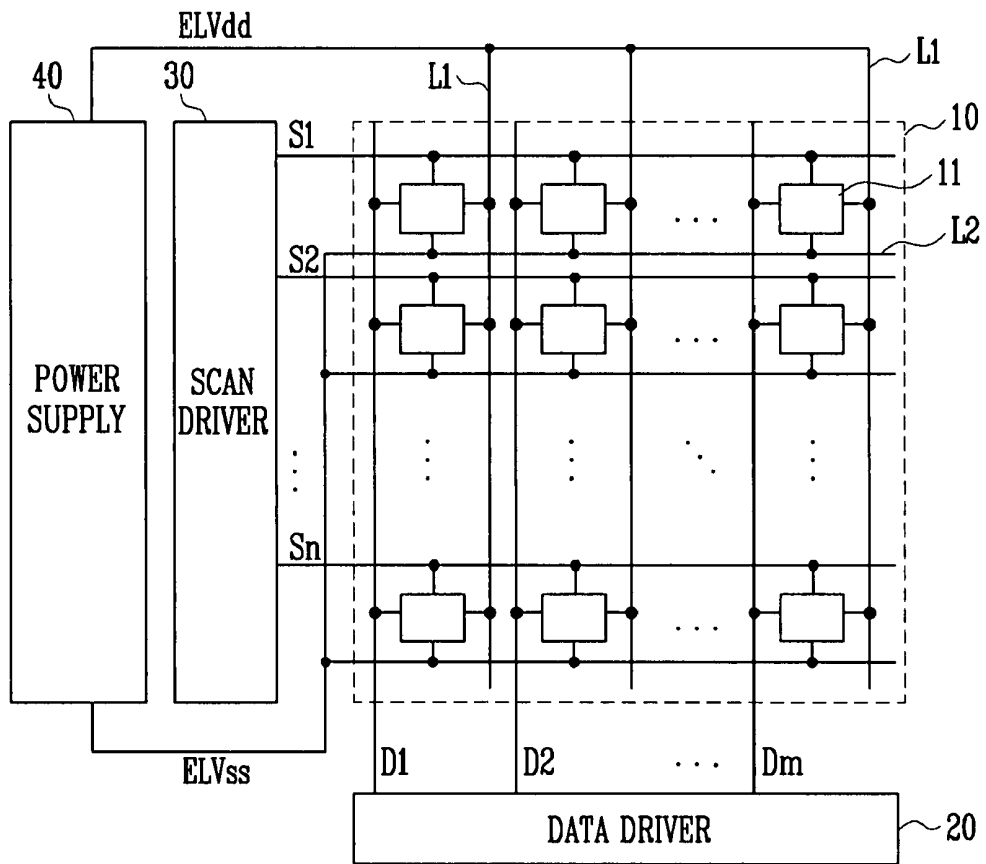

FIG. 2

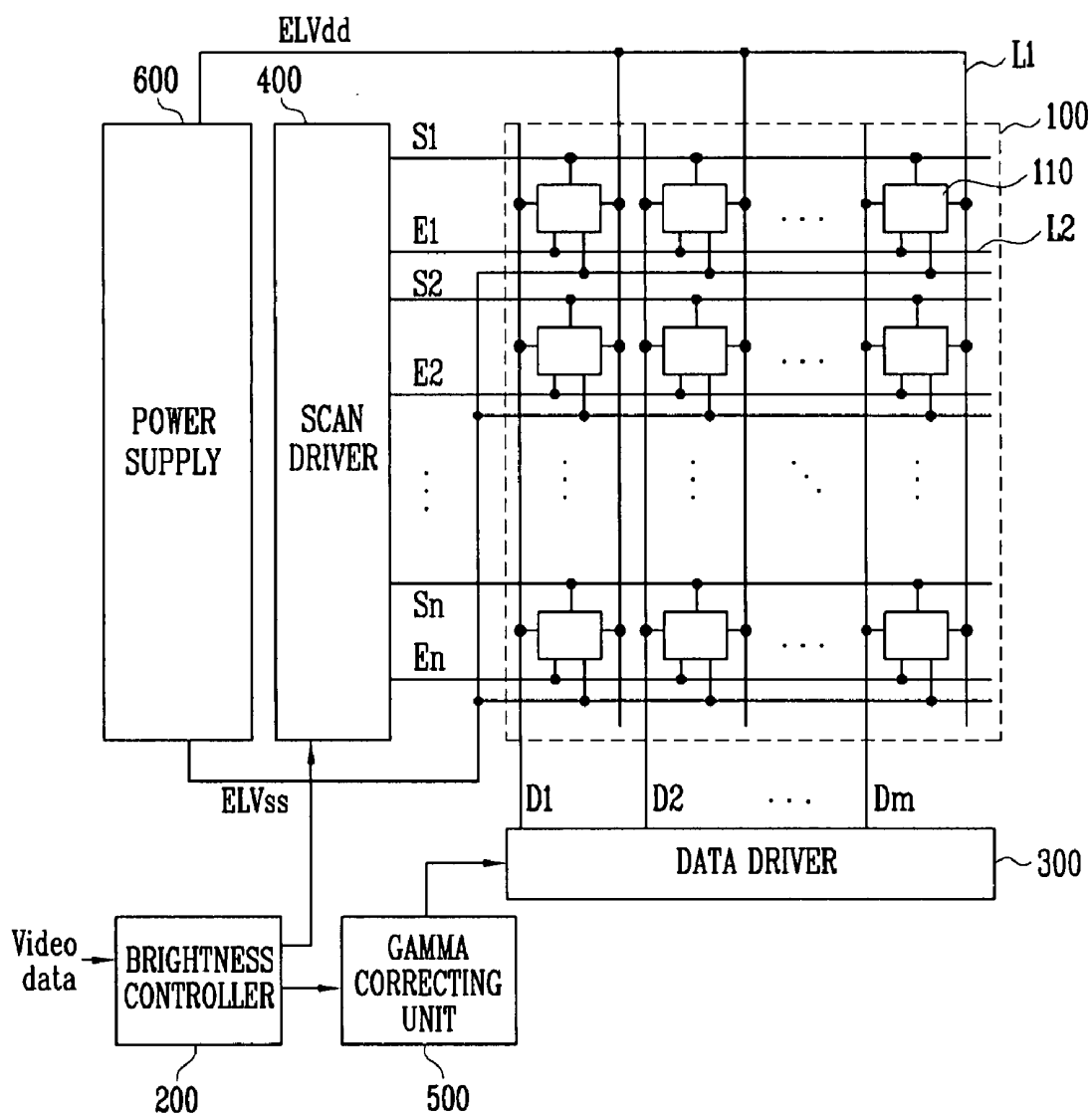

FIG. 3

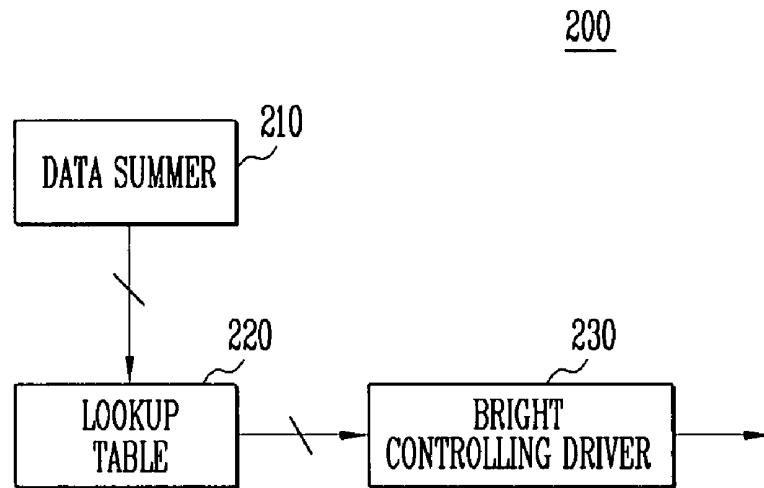

FIG. 4

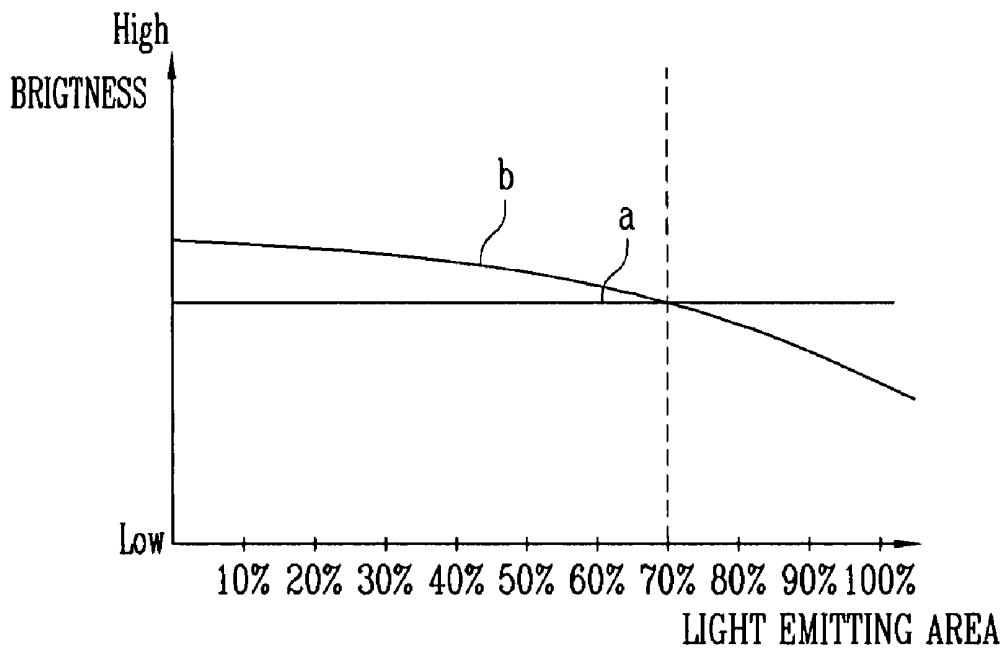
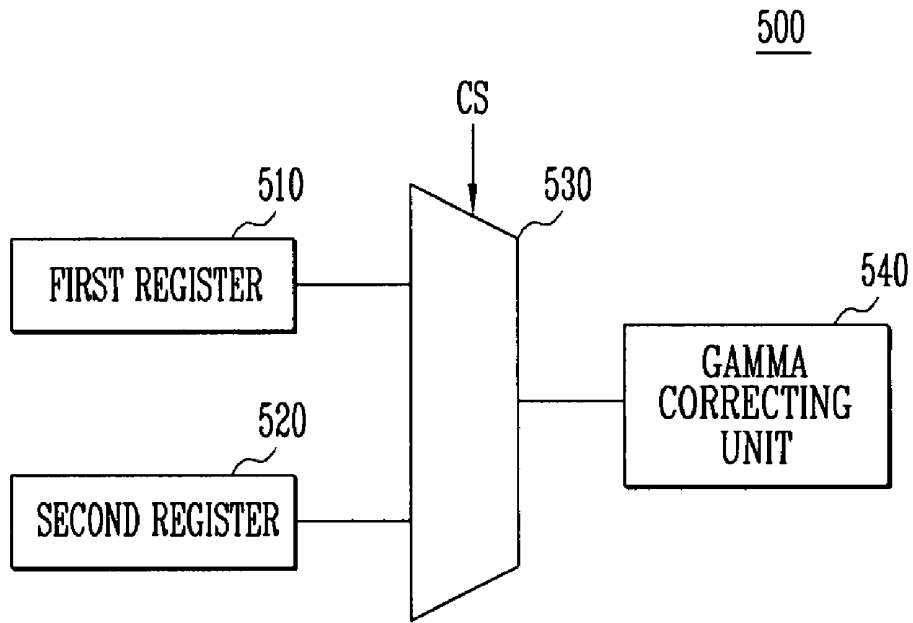

FIG. 5



3826290

053107

ORGANIC LIGHT EMITTING DIODE DISPLAY DEVICE AND DRIVING METHOD THEREOF

CROSS-REFERENCE TO RELATED APPLICATIONS

[0001] This application claims the benefit of Korean Patent Application No. 2006-0099349, filed on Oct. 12, 2006, in the Korean Intellectual Property Office, the disclosure of which is incorporated herein by reference.

BACKGROUND

[0002] 1. Field of the Invention

[0003] The field relates to an organic light emitting diode display device and a driving method thereof, and more particularly, to an organic light emitting diode display device and a driving method thereof capable of limiting brightness in accordance with a light-emitting area and making a light-emitting area in accordance with data signals

[0004] 2. Description of the Related Technology

[0005] Various flat panel display devices with reduced weight and volume as compared with a cathode ray tube have been developed. The flat panel display device uses, as a display region, a plurality of pixels arranged on a substrate in a matrix form and displays the pixels by selectively applying data signals to the pixels each connected to scan lines and data lines.

[0006] The flat panel display may be either a passive matrix type display device or an active matrix type display device. The active matrix type display device is capable of lighting pixels by selecting each pixel performance in terms of resolution, contrast, and operating speed.

[0007] Such a flat panel display device has been used as a display device for a portable information terminal, and the like such as a personal computer, a cellular phone, and a PDA, etc., or a monitor for various information apparatuses. Examples of such a flat panel display device include a LCD using a liquid crystal panel, an organic light emitting diode display device using an organic light-emitting diode, and a PDP using a plasma panel. Among others, an organic light emitting diode display device has been favored because of excellent capability of light-emitting efficiency, brightness and viewing angle and high speed response characteristic.

SUMMARY OF CERTAIN INVENTIVE ASPECTS

[0008] An organic light emitting diode display device and a driving method therefore is presented. The method is capable of reducing power consumption and improving quality of image by limiting the amount of current flowing to pixels and lowering the whole brightness, if an area displaying high brightness in the whole light-emitting area is large.

[0009] One aspect is an organic light emitting diode display device, including, a pixel unit including a plurality of pixels configured to display an image by receiving a plurality of scan signals, a plurality of light-emitting controlling signals, and a plurality of data signals, a scan driver configured to transmit the scan signals and the light-emitting controlling signals to the pixel unit, a data driver configured to generate the plurality of data signals based on video data and to transmit the data signals to the pixel unit, a brightness controller configured to selectively control a brightness

controlling range of the pixel unit based at least in part on the light-emitting area of the pixel unit and on the magnitude of the video data input in one frame, and a gamma correcting unit configured to control the portion of maximum luminance corresponding to full scale data by using any one of first gamma correcting values and second gamma correcting values, where the gamma correcting unit includes a first register configured to store the first gamma correcting values, a second register configured to store the second gamma correcting values, and a selector configured to select the first register and the second register according to data from the brightness controller.

[0010] Another aspect is a driving method of an organic light emitting diode display device. The method includes determining a brightness limiting range in response to a sum of frame data, selectively limiting brightness of pixels based at least in part on the brightness limiting range, and gamma correcting the data signals according to one of first gamma correcting values and second gamma correcting values.

[0011] Another aspect is an organic light emitting diode display device, including a brightness controller configured to selectively control a brightness controlling range based at least in part on the magnitude of video data input in one frame, and a gamma correcting unit configured to control the portion of maximum luminance corresponding to full scale data based on one of a plurality of gamma correcting values.

BRIEF DESCRIPTION OF THE DRAWINGS

[0012] FIG. 1 is a schematic view illustrating a organic light emitting diode display device;

[0013] FIG. 2 is a schematic view illustrating an organic light emitting diode display device;

[0014] FIG. 3 is a schematic view illustrating one example of a bright controller adopted in an organic light emitting diode display device;

[0015] FIG. 4 is a view showing brightness variation in accordance with a light-emitting area; and

[0016] FIG. 5 is a schematic view illustrating a gamma correcting unit shown in FIG. 2.

DETAILED DESCRIPTION OF CERTAIN INVENTIVE EMBODIMENTS

[0017] FIG. 1 is a structure view illustrating a organic light emitting diode display device. Referring to FIG. 1, an organic light emitting diode display device comprises a pixel unit 10, a data driver 20, a scan driver 30 and a power supply 40. NOTE: FIG. 1 should be changed to have reference numeral 40 indicate a power "supply" instead of "supplier."

[0018] The pixel unit 10 is arranged with a plurality of pixels 11, wherein the respective pixels 11 are connected with light-emitting diodes (not shown). The pixel unit is arranged with n scan lines S1, S2, . . . Sn-1, Sn that are formed in row directions and transmit scan signals, m data lines D1, D2, . . . , Dm-1, Dm that are formed in column directions and transmit data signals; m first power supply lines L1 supplying a first power source, and m second power supply lines L2 transmit a second power source ELVss having potential lower than that of the first power source ELVdd. The pixel unit 10 displays images with the light-emitting diodes according to the scan signals, the data signals, the first power source ELVdd, and the second ELVss.

[0019] The data driver 20 is configured to apply the data signals to the pixel unit 10 and is connected to the data lines D1, D2, . . . Dm-1, Dm of the pixel unit 10 to apply the data signals to the pixel unit 10.

[0020] The scan driver 30 is configured to sequentially output the scan signals and is connected to the scan lines S1, S2, . . . Sn-1, Sn to transmit the scan signals to the specific rows of the pixel unit 10. The specific rows of the pixel unit 10 receiving the scan signals receive the data signals input from the data driver 20 to display the images. A frame is completed once all of the rows are sequentially selected and driven.

[0021] The power supply 40 transfers the first power ELVdd and the second power source ELVss having potential lower than that of the first power source ELVdd to the pixel unit 10 to allow current corresponding to the data signal to flow to the pixel unit 10 by voltage difference of the first power source ELVdd and the second power source ELVss.

[0022] Some organic light emitting diode display devices as described above require a large amount of current for the pixel unit 10 when displaying at a high level of brightness and requires a low amount of current for the pixel unit 10 when displaying at low brightness. The power supply 40 must be capable of supplying at least the current required for displaying high brightness.

[0023] Also, in case that there are many regions to be displayed at high brightness, all supplied from a common power source, a problem occurs that quality of the displayed image is degraded.

[0024] FIG. 2 is a schematic view illustrating an organic light emitting diode display device according to one embodiment. Referring to FIG. 2, an organic light emitting diode display device comprises a pixel unit 100, a brightness controller 200, a data driver 300, a scan driver 400, a gamma correcting unit 500 and a power supply 600.

[0025] The pixel unit 100 is arranged with a plurality of pixels 110, wherein the respective pixels 110 are connected with light-emitting diodes (not shown). The pixel unit is arranged with n scan lines S1, S2, . . . Sn-1, Sn that are formed in row directions and transmit scan signals, n light-emitting controlling signals lines E1, E2, . . . , En-1, En that are formed in column directions and transmit light-emitting controlling signals; m data lines D1, D2, . . . Dm-1, Dm that are formed in column directions and transmit data signals, a first power source line L1 that transmits a first power source ELVdd to the pixels, and a second power source line L2 that transmits a second power source ELVss to the pixels. The second power source L2 is equivalently represented and may be formed in the whole regions of the pixel unit 100 to be electrically connected to the respective pixels 110.

[0026] The brightness controller 200 outputs brightness controlling signals to limit brightness of the pixel unit 100 displaying images so that the brightness does not exceed a predetermined range. The brightness of the pixel unit 100 may be higher when the area at high brightness is large than when the area at high brightness is smaller. However, when an area emitting light at high brightness is large, the pixel unit may advantageously be displayed with a lower brightness to save power.

[0027] The brightness can be changed in accordance with the change of the area emitting at high brightness by making the brightness limiting ranges depend on the area emitting at high brightness.

[0028] The brightness controller 200 determines the magnitude of the frame data that is the sum of video data input in one frame to determine if the magnitude of the frame data is large. The sum of the frame data gives an indication of the brightness of the frame. A high sum indicates a high brightness, and therefore a high current. Accordingly, the brightness controller 200 outputs the brightness controlling signals to limit brightness if the magnitude of the frame data signal is more than a threshold so that the brightness of the images displayed in the pixel unit 100 is reduced when displayed.

[0029] If the brightness of the pixel unit 100 is limited by the brightness controller 200, the amount of current flowing to the pixel unit 100 is limited so that high output of the power supply 500 is not needed. If the brightness of the pixel unit 100 is not limited, the light-emitting time of the light-emitting pixels may stay long in order to make the brightness high. In this situation, contrast ratio of the light-emitting pixel to the non-light-emitting pixel is large.

[0030] In another method of reducing the amount of current flowing to the pixel unit 100, the light-emitting time of the pixels is reduced so that the time of high current is reduced.

[0031] The brightness controller 200 controls the pulse widths of the light-emitting controlling signals transmitted through the light-emitting controlling signals lines E1, E2, . . . , En-1, En in order to control the light-emitting time of the pixel unit 100 and thus, controls the light-emitting time during the frame. If the pulse widths are long, the brightness controller 200 makes the amount of current flowing to the pixel unit 100 large so that the whole brightness of the pixel unit 100 is not reduced and if the pulse widths are short, it makes the amount of current flowing to the pixel unit 100 small so that the whole brightness of the pixel unit 100 is reduced.

[0032] The data driver 300 is configured to receive the video data having components of red, blue, and green, to generate the data signals, and to apply the data signals to the pixel unit 100. The data driver 300 is connected to the data lines D1, D2, . . . Dm-1, Dm of the pixel unit and is configured to apply the generated data signals to the pixel unit 100.

[0033] The scan driver 400 is configured to apply the scan signals and the light-emitting controlling signals to the pixel unit 100 and is connected to the scan lines S1, S2, . . . , Sn-1, Sn and the light-emitting controlling signal line E1, E2, . . . , En-1, En to transmit the scan signals and the light-emitting controlling signals to the specific rows of the pixel unit 100. The pixel 110 receiving the scan signals receives the data signals output from the data driver 300 and the pixel 110 receives the light-emitting controlling signals and emits light according to light-emitting controlling signals.

[0034] The scan driver 400 comprises a scan driving circuit configured to generate the scan signals and a light-emitting driving circuit configured to generate the light-emitting controlling signals. The scan driving circuit and the light-emitting driving circuit may be included in one component or separated into independent components.

[0035] The specific rows of the pixel unit 100 receiving the scan signals receive the data signals input from the data driver 300 and the light-emitting diodes are supplied with current corresponding to the light-emitting controlling signals and the data signals. The image is displayed by turning on the light-emitting elements.

[0036] The gamma correcting unit 500 improves visibility by controlling the relationship of image data and brightness. The gamma correcting unit 500 receives the data signals of which the relationship of image data and brightness is nonlinear to make the ratio of gray scale to brightness linearly display. The gamma correcting unit comprises a register and uses gamma correcting values set in the register to control the relationship of image data and brightness. Further, the gamma correcting unit comprises a register operating when the brightness controller is off and a register operating when the brightness controller is on. As a result, the relationship of image data and brightness of the data signals is adjusted by using the gamma correcting values stored in the register when the brightness controller 200 is on so that it has much higher value when the brightness controller 200 is on if the same data signals are entered.

[0037] The power supply 600 transfers the first power source ELVdd and the second power source ELVss to the pixel unit 400 to supply current corresponding to the data signals in the respective pixels according to the difference between the first power source ELVdd and the second power source ELVss.

[0038] FIG. 3 is a schematic view illustrating one example of a bright controller adopted in an organic light emitting diode display device. Referring to FIG. 3, the brightness controller 200 comprises a data summer 210, a lookup table 220, and a bright controlling driver 230.

[0039] The data summer 210 extracts information on frame data by summing video data having information on red, blue, and green input in one frame. It can be appreciated that if the data value of the frame data is large, the frame data includes many data displaying high gray scale and if the data value of the frame data is small, it includes few data displaying high gray scale. That is, the light-emitting area can be determined based on the magnitude of the frame data. In some embodiments, the light-emitting area is defined by the following equation 1.

$$\text{Light-emitting_area} = \frac{\sum \text{one_frame_data}}{\text{brightness_of_pixel_unit_light_emitting_at_full_white}} \quad (100)$$

[0040] The lookup table 220 specifies the widths of the light-emitting intervals of the light-emitting controlling signals according to the summed value of the frame data for some embodiments. The widths of the light-emitting intervals may be specified using the upper bits of the frame data. The light-emitting area may be deduced using, for example, the upper 5 bits of the frame data.

[0041] When the brightness of the pixel unit 100 is gradually increased and arrives at brightness exceeding predetermined brightness, the brightness of the pixel unit 100 is limited. Also, as the brightness of the pixel unit 100 is increased, the brightness limiting rate is getting larger, preventing the brightness of the pixel unit 100 from being excessively increased

[0042] If the brightness limiting rate is constant regardless of increasing the brightness of the pixel unit 100, when the pixel unit 100 displays very high brightness, the brightness is excessively limited so that a sufficiently bright screen can be provided, reducing brightness as a whole. Therefore, when the pixel unit 100 displays white as a whole, the

brightness limiting range is set at maximum to prevent the brightness of the pixel unit 100 from being reduced below its limiting range.

[0043] In some embodiments, if the magnitude of the frame data does not exceed a predetermined magnitude, the brightness is not limited. As a result, when the brightness is not high, the brightness is not limited.

[0044] Table 1 indicates an example of the lookup table. It can be appreciated from the table 1 that the light-emitting ratio according to the number of pixels emitting light at brightness exceeding predetermined brightness is limited to 50% of a maximum value.

TABLE 1

Upper 5 bit value	Frame Data as a portion of Full Scale	Portion of Maximum Luminance Corresponding to Full Scale Data.	Luminance	Width of Light emission control signal
0	0%	100%	300	325
1	4%	100%	300	325
2	7%	100%	300	325
3	11%	100%	300	325
4	14%	100%	300	325
5	18%	100%	300	325
6	22%	100%	300	325
7	25%	100%	300	325
8	29%	100%	300	325
9	33%	100%	300	325
10	36%	100%	300	325
11	40%	99%	297	322
12	43%	98%	295	320
13	47%	96%	287	311
14	51%	93%	280	303
15	54%	89%	268	290
16	58%	85%	255	276
17	61%	81%	242	262
18	65%	76%	228	247
19	69%	72%	217	235
20	72%	69%	206	223
21	76%	65%	196	212
22	79%	62%	186	202
23	83%	60%	179	194
24	87%	57%	172	186
25	90%	55%	165	179
26	94%	53%	159	172
27	98%	51%	152	165
28	—	—	—	—
29	—	—	—	—
30	—	—	—	—
31	—	—	—	—

[0045] If the frame data as a portion of full scale is 36% or less, the brightness is not limited and if the frame data as a portion of full scale exceeds 36%, the brightness is limited, so that when the frame data as a portion of full scale is increased, the brightness limiting rate is also increased. In order to prevent the brightness from being excessively limited, the brightness limiting rate is limited to 50% so that although most pixels of the pixel unit 100 emit light at maximum brightness, the brightness limiting rate should be 50% or less.

[0046] Table 2 indicates another example of the lookup table. It can be appreciated from the table 2 that the light-emitting ratio according to the number of pixels light-emitting at brightness exceeding predetermined brightness is limited to 33% of a maximum value.

TABLE 2

Upper 5 bit value	Frame Data as a portion of Full Scale	Portion of Maximum Luminance Corresponding to Full Scale Data	Luminance	Width of Light emission control signal
0	0%	100%	300	325
1	4%	100%	300	325
2	7%	100%	300	325
3	11%	100%	300	325
4	14%	100%	300	325
5	18%	99%	298	322
6	22%	98%	295	320
7	25%	95%	285	309
8	29%	92%	275	298
9	33%	88%	263	284
10	36%	83%	250	271
11	40%	79%	237	257
12	43%	75%	224	243
13	47%	70%	209	226
14	51%	64%	193	209
15	54%	61%	182	197
16	58%	57%	170	184
17	61%	53%	160	173
18	65%	50%	150	163
19	69%	48%	143	155
20	72%	45%	136	147
21	76%	43%	130	141
22	79%	41%	124	134
23	83%	40%	119	128
24	87%	38%	113	122
25	90%	36%	109	118
26	94%	35%	104	113
27	98%	34%	101	109
28	—	—	—	—
29	—	—	—	—
30	—	—	—	—
31	—	—	—	—

[0047] If the frame data as a portion of full scale is 14% or less, the brightness is not limited and if the Frame Data as a portion of Full Scale exceeds 14%, the brightness is limited, so that when the area light-emitting at maximum brightness is increased, the brightness limiting rate is also increased. In order to prevent the brightness from being excessively limited, the brightness limiting rate is limited to 33% so that although most pixels of the pixel unit 100 emit light at maximum brightness, the brightness limiting rate should not be 33% or less. The light-emitting area indicated in tables 1 and 2 is calculated using the upper 5-bit value of one frame data.

[0048] The brightness controlling driver 230 receives the upper 5-bit value to output the brightness controlling signals. The brightness controlling signals are input to the scan driver 400 to control the scan driver 400 so that the scan driver 300 outputs the light-emitting controlling signals according to the brightness controlling signals. In particular, the brightness controlling signals are input to the light-emitting controlling circuit to output the light-emitting controlling signals in accordance with the brightness controlling signals.

[0049] In some embodiments, the maximum light-emitting intervals of light-emitting controlling signals are set to 325. Because 8 bits can represent 256 values and 9 bits can represent 512 numbers, in order to generate the light-emitting intervals of the light-emitting controlling signals as indicated in the table 1, it is preferable that the brightness controlling signals outputs 9-bit signals. The brightness

controlling signals may use a start pulse and the widths of the light-emitting control signals may be determined.

[0050] FIG. 4 is a view showing maximum brightness in accordance with a light-emitting area. Referring to FIG. 4, a horizontal axis indicates a light-emitting area and a vertical axis indicates maximum brightness in accordance with a light-emitting area, wherein a indicates a case that maximum brightness is constant independent of a light-emitting area and b indicates a case that maximum brightness is changed in accordance with a light-emitting area, and maximum brightness is to be higher by using the gamma correcting values when a light-emitting area is small.

[0051] First, the case of a is a case that the brightness controller is off. In this case, even though the light-emitting area is changed, the brightness is not changed. In the case that the brightness of the pixels is high, when the light-emitting area is small the pixels light-emitting at high brightness are not many so that power consumption is not large, however, when the light-emitting area is large the pixels light-emitting at high brightness is many that power consumption is large. Therefore, the power supply 600 is applied with considerable load so that it needs to have a large capacity. Also, when the light-emitting area is large, it can emit light at too high brightness so that dazzling phenomenon can be caused.

[0052] The case of b is a case that the brightness controller 200 is on. In the case of b, brightness values corresponding to gray scales are higher than that of the case of a, and the gamma correction is performed by using different gamma correcting values from gamma correcting values applied in the case of a. If, for example, the light-emitting area is 70% or more, the maximum brightness is lower than that of the case of a and if the light-emitting area is 70% or less, the maximum brightness is higher than that of a. The maximum brightness is to be high in portions that the light-emitting area is 70% or less. The brightness is to be high when the light-emitting area is small. The brightness of bright portions of dark portions and bright portions is very high to make brightness difference between the dark portions and the bright portions large so that contrast is increased. Accordingly, the bright portions of the images displayed on the pixel unit are displayed much brighter. And, if the brightness in the portions that the light-emitting area is 70% or more is to be low, the brightness is limited so that dazzling phenomenon is reduced.

[0053] Contrast is changed in accordance with the light-emitting area so that visibility is improved. Therefore, in some embodiments, the gamma correcting values are adjusted to change the brightness values, as shown in b. As a result, power consumption is reduced, contrast is increased, and visibility is improved.

[0054] FIG. 5 is a schematic view illustrating a gamma correcting unit shown in FIG. 2. Referring to FIG. 5, the gamma correcting unit 500 comprises a first register 510, a second register 520, a selector 530, and a gamma correcting circuit 540.

[0055] The first register 510 is configured to store first gamma correcting values of data signals and is selected to correct the data signals when the brightness controller is not operated. The first gamma correcting values are general correcting values for changing a nonlinearly input ratio of brightness of gray scale to a linear ratio of brightness of gray scale.

[0056] The second register 520 is configured to store second gamma correcting values of data signals and is selected to correct the data signals when the brightness controller 200 is operated. The data signals corrected by the second gamma correcting values stored in the second register 520 can display brightness higher than the data signals corrected by the first gamma correcting values stored in the first register 510.

[0057] A selector 530 is configured to select either of the first register 510 and the second register 520 and can select one of the first register 510 and the second register 520 by using selecting signals from the brightness controller 200.

[0058] A gamma correcting circuit 540 is configured to control the ratio of brightness to gray scale and controls voltage difference among the data signals by receiving gamma correcting coefficients from one of the first register 510 or the second register 520, controlling the brightness corresponding to the gray scale.

[0059] With the organic light emitting diode display device and a driving method thereof, power consumption of the organic light emitting diode display device can be reduced and the maximum output of the power supply can be reduced to save its manufacturing cost. Also, contrast is increased to improve visibility.

[0060] Although a few embodiments have described using specific terminologies and examples, it would be appreciated by those skilled in the art that various modification and changes might be made in this embodiment without departing from the scope and spirit of the invention.

What is claimed is:

1. An organic light emitting diode display device, comprising;

a pixel unit comprising a plurality of pixels configured to display an image by receiving a plurality of scan signals, a plurality of light-emitting controlling signals, and a plurality of data signals;

a scan driver configured to transmit the scan signals and the light-emitting controlling signals to the pixel unit;

a data driver configured to generate the plurality of data signals based on video data and to transmit the data signals to the pixel unit;

a brightness controller configured to selectively control a brightness controlling range of the pixel unit based at least in part on the light-emitting area of the pixel unit and on the magnitude of the video data input in one frame; and

a gamma correcting unit configured to control the portion of maximum luminance corresponding to full scale data by using any one of first gamma correcting values and second gamma correcting values,

wherein the gamma correcting unit comprises:

a first register configured to store the first gamma correcting values;

a second register configured to store the second gamma correcting values; and

a selector configured to select the first register and the second register according to data from the brightness controller.

2. The organic light emitting diode display device as claimed in claim 1, wherein the second register is selected when the brightness controller controls the brightness controlling range.

3. The organic light emitting diode display device as claimed in claim 1, wherein the time that the light-emitting area emits light is controlled based at least in part on the magnitude of the frame data.

4. The organic light emitting diode display device as claimed in claim 1, wherein the second gamma correcting values are configured to set brightness higher than the first gamma correcting values.

5. The organic light emitting diode display device as claimed in claim 1, wherein the scan driver comprises:

a scan driving circuit configured to transmit the scan signals; and

a light-emitting control driving circuit configured to transmit the light-emitting controlling signals,

wherein the brightness controller is configured to control the light-emitting control driving circuit.

6. The organic light emitting diode display device as claimed in claim 1, wherein the brightness controller comprises:

a data summer configured to sum the data signals input for one frame interval;

a lookup table configured to store the brightness limiting range corresponding to the summed values of the data signals; and

a brightness controlling driver configured to control the light emitting time of the pixel unit based on a brightness limiting range generated in response to the data signals summed in the data summer.

7. The organic light emitting diode display device as claimed in claim 6, wherein the pulse widths of the light emitting controlling signals are controlled by the brightness controller.

8. The organic light emitting diode display device as claimed in claim 1, further comprising a power supply configured to supply power to the pixel unit.

9. The organic light emitting diode display device as claimed in claim 1, wherein the brightness limiting range is configured to limit the amount of current flowing to the pixel unit.

10. The organic light emitting diode display device as claimed in claim 9, wherein the amount of current is controlled by the light-emitting time of the pixels.

11. A driving method of an organic light emitting diode display device, the method comprising:

determining a brightness limiting range in response to a sum of frame data;

selectively limiting brightness of pixels based at least in part on the brightness limiting range; and

gamma correcting the data signals according to one of first gamma correcting values and second gamma correcting values.

12. The driving method of an organic light emitting diode display device as claimed in claim 11, wherein the first gamma correcting values are selected when the brightness is not limited based at least in part on the brightness limiting range.

13. The driving method of an organic light emitting diode display device as claimed in claim 11, wherein the brightness corresponding to the data signals corrected according to the second gamma correcting values is corrected to be higher than that of the brightness corresponding to the data signals corrected according to the first gamma correcting values.

14. The driving method of an organic light emitting diode display device as claimed in claim **11**, wherein the brightness limiting range of the pixels corresponds to the light-emitting time of the pixels.

15. An organic light emitting diode display device, comprising:

a brightness controller configured to selectively control a brightness controlling range based at least in part on the magnitude of video data input in one frame; and

a gamma correcting unit configured to control the portion of maximum luminance corresponding to full scale data based on one of a plurality of gamma correcting values.

16. The organic light emitting diode display device as claimed in claim **15**, wherein the plurality of gamma correcting values includes first and second gamma correcting values, and the second gamma correcting values are used when the brightness controller controls the brightness controlling range.

17. The organic light emitting diode display device as claimed in claim **15**, wherein the time that a portion of the display emits light is controlled based at least in part on the brightness controlling range.

18. The organic light emitting diode display device as claimed in claim **15**, wherein the current by which a portion of the display emits light is controlled based at least in part on the brightness controlling range.

19. The organic light emitting diode display device as claimed in claim **15**, wherein the second gamma correcting values are configured to set brightness higher than the first gamma correcting values.

20. The organic light emitting diode display device as claimed in claim **15**, further comprising a data driver, configured to modify image data based on the brightness controlling range.

* * * * *

专利名称(译)	有机发光二极管显示装置及其驱动方法		
公开(公告)号	US20080088548A1	公开(公告)日	2008-04-17
申请号	US11/901090	申请日	2007-09-13
[标]申请(专利权)人(译)	李在SUNG LEE李昌勋		
申请(专利权)人(译)	李在SUNG LEE李昌勋		
当前申请(专利权)人(译)	李在SUNG LEE李昌勋		
[标]发明人	LEE JAE SUNG LEE CHANG HOON		
发明人	LEE, JAE SUNG LEE, CHANG HOON		
IPC分类号	G09G3/30		
CPC分类号	G09G3/2014 G09G3/3225 G09G2300/0861 G09G2360/16 G09G2320/0673 G09G2330/021 G09G2320/0626		
优先权	1020060099349 2006-10-12 KR		
外部链接	Espacenet USPTO		

摘要(译)

公开了一种有机发光二极管显示装置。该装置包括：亮度控制器，被配置为至少部分地基于在一帧中输入的视频数据的大小来选择性地控制亮度控制范围；以及伽马校正单元，被配置为控制与基于满量程数据的最大亮度的部分。在第一伽马校正值和第二伽马校正值之一上。

